



ZRV Blower

Installation and Operating Manual



CE
RoHS

ZRV Blower Technical Manual

Thank you for choosing our ZRV Blower ! Please read this manual carefully before using the product.



IMPORTANT NOTE

In order to ensure the normal working life of the ZRV Blower , and at the same time ensure the safety of your machine and the continuity of production, please hand this precaution and operation manual to the personnel of your technical department and the end user to maximize the security and high-efficient performance of the machine.

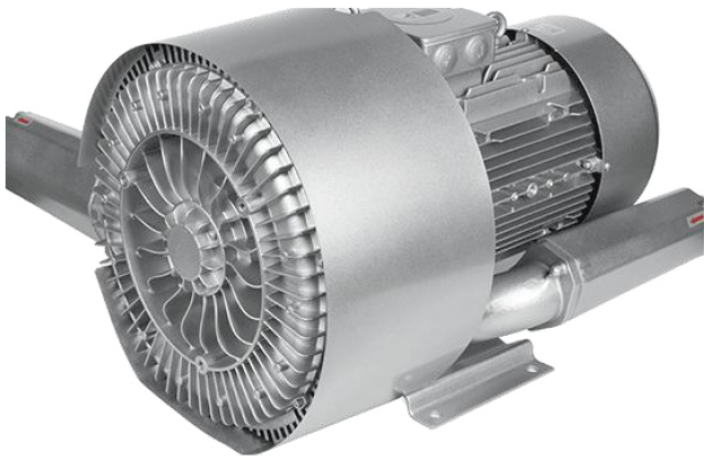

APPLICATIONS

- ✓ Pneumatic conveying systems
- ✓ Lifting and holding of parts by vacuum
- ✓ Packing machines
- ✓ Aeration of sewage-treatment plants
- ✓ Filling of bags/bottles/hoppers
- ✓ Soil remediation
- ✓ Thermoforming
- ✓ Sorting/enveloping of letters
- ✓ Food-processing
- ✓ Laser printers
- ✓ Dental suction equipments
- ✓ Paper processing
- ✓ Printers/copiers
- ✓ Textile machines
- ✓ Aeration of fish ponds
- ✓ air analysis
- ✓ Swimmingpool equipment/whirlpools

ZRV Blower Operating Principle

The impellers in the our machines are mounted directly on the motor shaft for non-contact compression entirely without friction. Maximum operational reliability, even at high differential pressures, is ensured by the arrangement of the bearings outside the compression chamber.

The air is taken in through the inlet ①. As it enters the side channel ②, the rotating impeller ③ imparts velocity to the air in the direction of rotation. Centrifugal force in the impeller blades accelerates the air outward and the pressure increases. Every rotation adds kinetic energy, resulting in the further increase of the pressure along the side channel. The side channel narrows at the rotor, sweeping the air off the impeller blades and discharging it through the outlet silencer ④ where it exits the ZRV Blower .

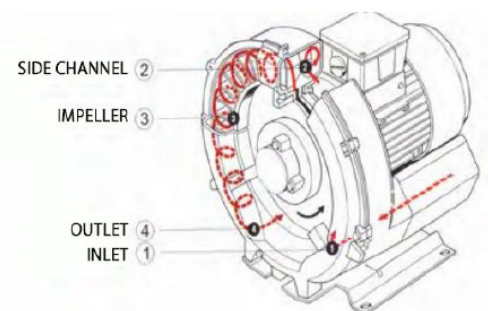

GERMAN TECHNOLOGY

With high inlet volume flow up to 2,500m³/h and a differential pressure up to 780mbar, low noise all rounders have earned reputation and convinced thousands of customers all over the world. Reliable, low-maintenance and durable and are the first choice for many applications in mechanical engineering.

When coupled with a frequency converter, the performance of ZRV Blower can be increased dramatically.

Our ZRV Blowers are UL/CCC/CE certified and can be used without further testing all over the world.

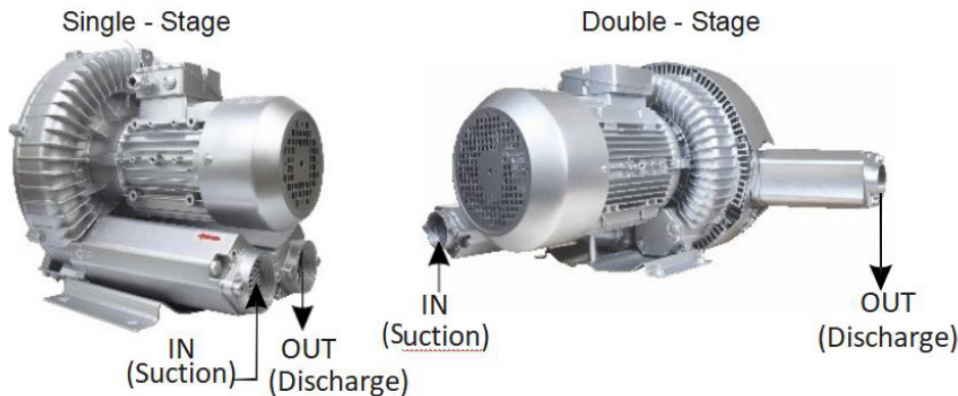

ZRV Blower Pressure and Maximum Pressure

Pressure is the basic parameter of ZRV Blowers. Our ZRV Blower is well-known for its relatively high pressure. At present, our ZRV Blower can provide a single pressure range of 7~100KPa.

When the air inlet or outlet pipe is fully enclosed, the maximum negative pressure or maximum positive pressure of the air ring vacuum pump can be obtained. Under normal circumstances, we do not recommend this use. If it is necessary, please use a pressure relief valve and install it correctly to protect the life of the vortex ZRV Blower. Please refer to the corresponding chapter for the use of pressure relief valve.

Flow rate and maximum flow rate of ZRV Blower

Flow rate is also the basic parameter of vortex ZRV Blower. In this regard, we have many models, which can provide different flow rates under the same power. At present, our ZRV Blower can provide a flow range of 47~2330m³/h.

The maximum flow rate of the fan can be obtained when the air inlet and outlet pipes are in a fully open state. Except for on-site ventilation, it is impossible to obtain this parameter on other occasions.

ZRV Blower Pressure, flow and power relationship

Pressure and flow are complementary, they are a contradictory relationship. Specifically, the flow rate of

the vortex ZRV Blower will decrease with the increase in pressure, but the power used by it will increase with the increase in pressure, and vice versa.

If in the selection, we first select the use pressure along the pressure coordinate on the "pressure-flow curve graph", and then select the use flow along the flow coordinate, so we get "the straight line intersection point of the use pressure and the use flow", We use this "operating point" as a benchmark to select the vortex ZRV Blower corresponding to the curve above the operating point. Under normal circumstances, the vortex ZRV Blower selected in this way can meet your site requirements.

Under normal circumstances, other similar products are marked with the maximum pressure and maximum flow that can be provided. When we select the ZRV Blower, we determine the model of the ZRV Blower "according to the use pressure and use flow". Therefore, you need to pay attention to the difference. Also, because the positive pressure and negative pressure provided by the same type of ZRV Blower are sometimes different, you should also pay attention to the corresponding curve when selecting the model.

The performance curve of ZRV Blower is measured under the working condition of 15°C air suction and 1013mbar exhaust pressure. The tolerance is $\pm 10\%$. When the suction air and ambient temperature do not exceed 25°C, the curve can still be reached. The total pressure difference shown.

The pressure and flow rate indicated on the nameplate of vortex ZRV Blower are the maximum working pressure and maximum flow rate that vortex ZRV Blower can provide. Please pay attention.

OPTIONAL ACCESSORIES:

(1) Pressure/Vacuum Relief Valve

The vacuum relief valve controls inlet pressure when the machine is used in vacuum duty.

The pressure relief valve controls pressure when the machine is used in pressure duty.



(2) Inlet Filter

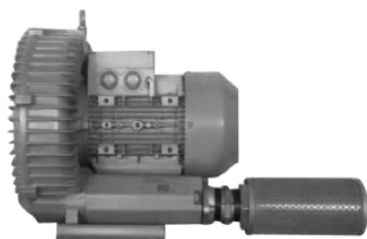

The inlet filter protects the machine against dust and other solids in process gas. The inlet filter is available

with a cartridge.

INSTALLATION CONDITIONS

1. Make sure that the environment of the machine is not potentially explosive.
2. Make sure that the ambient conditions comply with the technical data.
3. Make sure that the environment conditions comply with the protection class of the motor.
4. Make sure that the installation space or location is well ventilated such that sufficient cooling of the machine is provided.
5. Make sure that cooling air inlets and outlets are not covered or obstructed and that the cooling air flow is not affected adversely in any way.
6. Make sure that the machine is placed or mounted horizontally/vertically, with a maximum deviation of 25 mm in any direction.
7. Make sure that the machine is placed or mounted horizontally on a flat surface.
8. Make sure that all provided covers, guards, hoods, etc. are mounted.
9. If the machine is installed at an altitude greater than 1000 meters above sea level, contact your sales representative. The motor should be derated or the ambient temperature limited.
10. If the machine is installed outdoor, provide a protective cover against the weathering effects.

CONNECTING THE LINES & PIPES

1. Remove all protective caps before installation.
2. Make sure that the connection lines cause no stress on the machine's suction/discharge openings. If necessary use flexible joints.
3. Make sure that the line size of the connection lines over the entire length is at least as large as the suction/discharge openings of the machine.
4. In case of very long connection lines it is advisable to use larger line sizes in order to avoid a loss of efficiency. Seek advice from your sales representative.

(1) Suction Connection - NOTES

Ingress of foreign objects or liquids. **Risk of damage to the machine!**



If the inlet air contains dust or other foreign solid particles: Install a suitable filter (5 micron or less) upstream from the machine.

(2) Discharge Connection - NOTES



Depending on the specific order, other connection dimensions may apply. Make sure that the discharge air flows without obstruction. Do not shut off or throttle the discharge line.

Power connection of ZRV Blower

ELECTRICAL CONNECTION

DANGER



Live wires. Risk of electrical shock !

Electrical installation work must only be executed by qualified personnel.
 Make sure that the power supply for the motor is compatible with the data on the nameplate of the motor.
 Provide overload protection according to EN60204-1 for the motor.
 Make sure that the motor of the machine will not be affected by electric or electromagnetic disturbance from the mains; if necessary seek advice from your sales representative.
 Connect the protective earth conductor.
 Electrically connect the motor.

NOTICE



Incorrect connection. Risk of damage to the motor !

The wiring diagrams given below are typical. Check the inside of the terminal box for motor connection instructions/diagrams.

(1) Wiring Diagram Single - Phase Motor

Low voltage:

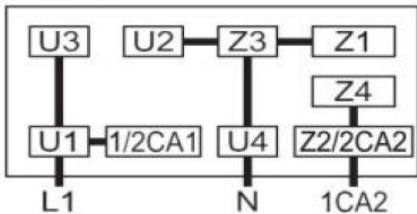

High voltage:

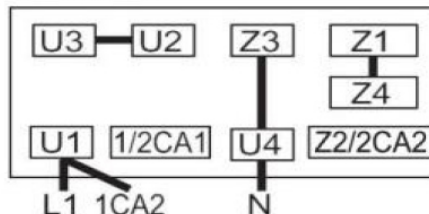

Low voltage (with motor protection):

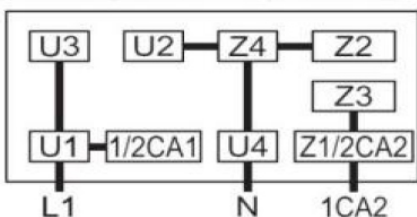

High voltage (with motor protection):

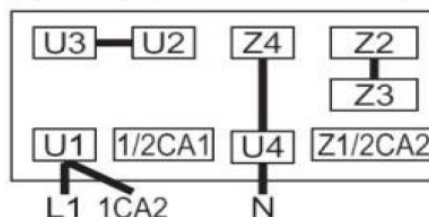

Connection motor protection:

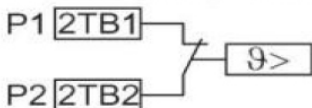

(2) Wiring Diagram Three-Phase Motor

NOTICE



Incorrect direction of rotation.

Risk of damage to the machine!

Operation in the wrong direction of rotation shall destroy the machine in a short time.

Prior to start-up, ensure that the machine is operated in the right direction.

If the rotation of the motor is in wrong direction:

Switch any two of the motor phase wires.

Delta connection (low voltage):

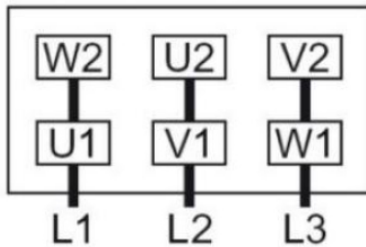

Star connection (high voltage):

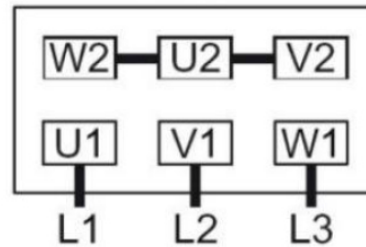

COMMISSIONING

NOTICE



Lubricating a dry running machine (Process Chamber)

Risk of damage to the machine!

Do not lubricate the process chamber of the machine with oil or grease.

CAUTION



During operation the surface of the machine may reach temperatures of more than 70°C.

Risk of burns!

Avoid contact with the machine during and directly after operation.

CAUTION



Noise of running machine

Risk of damage to hearing!

If persons are present in the vicinity of a non noise insulated machine over extended periods:

Make sure that ear protection is being used.

Make sure that the installation conditions are complied with.

Switch on the machine:

Make sure that the maximum permissible number of starts does not exceed 6 starts per hour.

Make sure the working/pause periods are equal with multiple starts per hour.

As soon as the machine is operated under normal operating conditions:

Measure the motor current and record it as reference for future maintenance and trouble shooting work.

When you receive our air ring vacuum pump, please wire it as follows. Wiring must be performed by professional electrical technicians who have obtained corresponding qualifications!

If it is a 380V air ring vacuum pump, when you disassemble the junction box, our factory default wiring method is the 3-phase 380V wiring method, you can directly connect the 3-phase 380V power supply. If other voltages are used, please deal with it according to the nameplate.

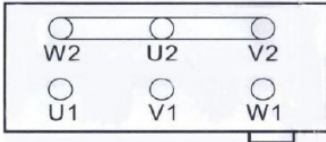

The factory is star connection: directly connect to 3-phase 380V, in U1, V1, W1; mostly used for low-power air ring vacuum pumps

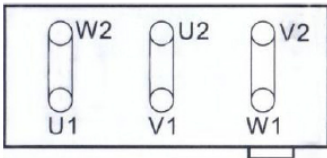

The factory is delta connection: directly connected to 3-phase 380V, in U1, V1, W1; mostly used for three-phase high-power air ring vacuum pumps

If it is a 220V air ring vacuum pump, after disassembling the junction box, first confirm a reference direction, the air barrel is on the left, the air inlet is on the right, counting from the right to the left, the first and second terminals on the terminal block are 220V power terminal.

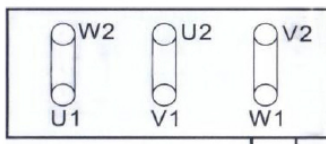

The factory is "delta" connection: directly connected to single-phase 220V, in V1, W1; mostly used for single-phase low-power air ring vacuum pumps

It is strongly recommended that when using the air ring vacuum pump, do not reverse the air ring vacuum pump for continuous operation. This may cause some unpredictable failures.

If reversal is necessary and the reversal time is very short, then for air ring vacuum pumps that use three-phase power, you can directly swap any two power lines in the order. And for the air ring vacuum pump with single-phase power supply, we recommend that you change the direction of rotation of the air ring vacuum pump by changing the head and tail positions of the secondary winding coil, and the efficiency becomes lower when the reverse operation is performed.

Sometimes, you receive our high-power air ring vacuum pump, but the coil is star connection (three-phase 220V/380V dual voltage) when leaving the factory, and star-delta decompression/decompression starting is not allowed. At this time, we recommend that you use a soft starter or frequency converter to start the air ring vacuum pump. If you must start it directly, it is recommended that you start the air ring vacuum pump with no load.

Before electrical wiring of the air ring vacuum pump, please make sure that the power supply voltage is consistent with the operating voltage of the motor, and whether the motor terminal connection method is correct (refer to the coil voltage withstand method indicated on the nameplate), and the wiring terminal is indeed firmly fixed, Confirm that there is no short-circuit phenomenon, so as to avoid leakage and install a grounding wire. (The 6 terminals of the terminal are not connected to each other and need to be connected by copper sheets.)

The load current of the motor will change with the change of the air pressure used by the air ring vacuum pump. When wiring, the overload protection switch of this model should be installed and used under the rated full load current (A) to prevent the motor from burning. (For the rated full load current, please refer to the value indicated on the motor nameplate.)

ZRV Blower Temperature

Under normal circumstances, our ZRV Blower allows the inlet air temperature to be below 50 degrees. Under special circumstances, the maximum allowable air inlet temperature is 70 degrees. At this time, special customized machines are required.

If you use our ZRV Blower for the following occasions, vacuum adsorption/vacuum lifting/vacuum handling/industrial vacuuming/vacuum feeding/waste collection/air knife drying/water treatment aeration/plating stirring/positive pressure conveying, Or similar load occasions, in your case, the temperature of our vortex ZRV Blower will be relatively high, especially the temperature of the air barrel surface, which may reach 90-100 degrees, which is normal.

When used in the above occasions, the temperature will rise to 90-100 degrees in about 15-40 minutes. Depending on the pressure used on site, the temperature rise time is also different. When used in a fully enclosed manner, it takes about 10 minutes without human hands to touch the surface of the wind bucket, and the temperature is above 80 degrees.

When using in the above occasions, we need to ask you to check whether the surface temperature of the motor is below 100 degrees, and whether the running current of the motor is within the current range indicated on the nameplate. As long as these two items meet the requirements, it is normal. Please rest assured. use! And you can let the vortex ZRV Blower run continuously without stopping for 24 hours.

As the vortex ZRV Blower may generate high temperatures during operation, it is necessary to avoid touching its casing to avoid burns.

If the site conditions may cause the vortex ZRV Blower to produce high temperatures, pay attention to avoid using the vortex ZRV Blower in a small, closed, air-less space, and strengthen cooling measures.

Working environment of ZRV Blower

ZRV Blowers are suitable for industrial sites in the range of -10 to +50 degrees. If you need to use them in other sites, please take corresponding measures.

ZRV Blower filter

As long as there is foreign matter such as dust on the use site, and it may be sucked into the inside of the

vortex ZRV Blower , a filter needs to be installed. In principle, we recommend using filters at any use site.

For different sites, we provide filters with different filtration accuracy. To ensure that we meet the needs of our customers. Our MF series filters have a filtration accuracy of 100 meshes, which are used in general industrial sites; HF series are 1000 meshes, which are used in industrial sites with a lot of dust or high air requirements.

If it is an industrial vacuum cleaner/powder conveying site, you cannot directly use the filter provided by us! Industrial vacuum cleaners or similar machines need to be installed with a dust filter device in front of our HF series filter, or a separate filter system must be made.

Special attention should be paid to hard objects, dust particles, fibers, water droplets, etc., which should be removed before the air enters the air ring vacuum pump, and can be handled by dust bags. If a filter device (especially of this type) is used in the middle of the pipeline, in order to avoid pressure loss, please use a large-area filter device and regularly clean the contaminated debris in the filter device.

Regarding the service life of the filter, our ZRV Blower series filter can be removed and washed directly under the tap with water; while the HF series filter can only be cleaned with a brush and replaced with a new filter element regularly. Under normal circumstances, a new filter element needs to be replaced after three months of use; the longest service life is six months; if there is a large amount of dust on site, the time to replace the filter element needs to be advanced according to the situation.

Pressure relief valve of ZRV Blower

The pressure relief valve is an unloading valve. When the pressure of the vortex ZRV Blower exceeds the pressure set by the pressure relief valve, the pressure relief valve will automatically open to release the excess pressure to protect the ZRV Blower .

It has two methods of use, positive pressure and negative pressure. When you use negative pressure, install the pressure relief valve on the air inlet pipe with a three-way. At the same time, install the corresponding filter at the inlet of the pressure relief valve according to the dust situation on the spot; and when you use positive pressure At that time, the pressure relief valve is installed on the air outlet pipe with a three-way. There is a pressure adjusting screw on the pressure relief valve, and the working pressure needs to be adjusted during use. When she tightens it inward, the protection pressure increases; when she loosens it outside, the protection pressure decreases.

After you install the pressure relief valve correctly, you also need to check whether the pressure relief valve is working properly. If you find that the pressure is not enough after installing our pressure relief valve normally, this may be due to the low power selection. It is recommended that you replace the vortex ZRV Blower with a higher power and then install the pressure relief valve.

Another accessory related to the pressure relief valve is the loss-of-pressure protection switch, which will

greatly reduce your loss in the greatest possible situation. We strongly recommend that you choose to install it. Please consult our professional technicians for details.

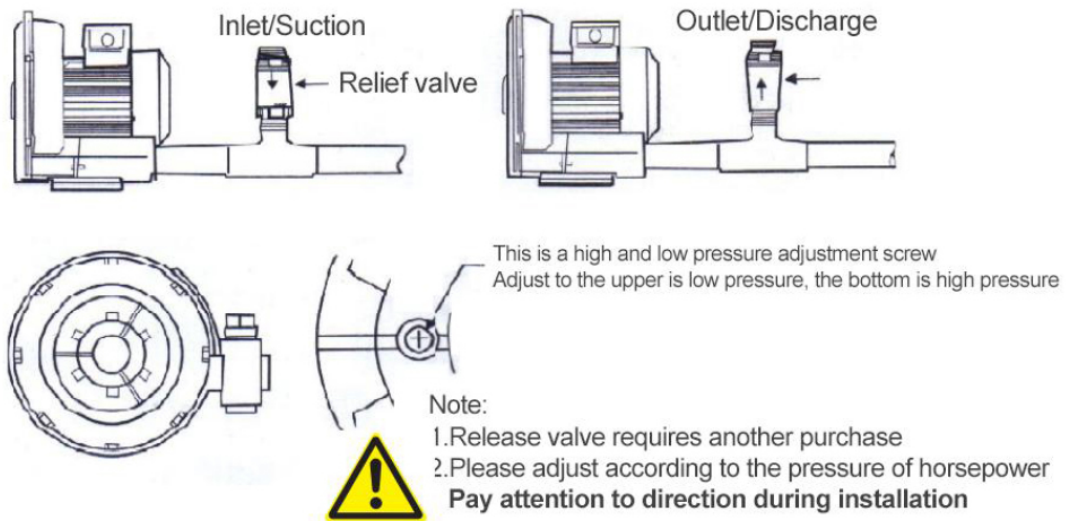

Silencer of air ring vacuum pump

We gave a melonmeter built-in silencer, which had reduced the noise of our garden vacuum pump to a lower level.

If your site has higher requirements for noise, please use our Si series external silencer. Under normal circumstances, use our Si series external silencer to reduce noise around 5dB (decibel).

The Si series external silencer is installed at the end of the air supply or the air supply pipe (from the air ring vacuum pump blow or out of the exhaust "), in general, the silencer is installed at the end of the air supply pipe (the air ring vacuum pump is the most Far); if you use a blowing function, use the opposite method installation.

If you use a Si series external silencer, you can't meet your live noise requirements. We recommend that you make a soundproker according to the conditions itself. Specifically, it is to use a box to vacuum pump housings, and then silence the cotton in six papers inside the box. (Usually, a relatively dense silencing cotton having a thickness of 20 mm and a wave peak is 15 mm can be used. At this time, pay attention to the ventilation heat of the air ring vacuum pump, the minimum distance in each direction, the temperature of the air air, etc.

Piping mode and operation attention of ZRV Blower

As the vortex ZRV Blower may generate high temperatures during operation, high-quality durable materials that can withstand the pressure and high temperature should be used when piping. The piping must be used to avoid air leakage or foreign objects in the pipeline.

Do not allow the pipeline to operate completely closed. When the pipeline has a necking, make sure that the maximum necking cannot exceed 2/3 of the original, and a pressure relief valve must be installed. If it must be close to the closed pressure during use, a pressure relief valve must be installed.

If the pipeline is running in a closed condition, considering the sharp rise in temperature of the vortex ZRV Blower, continuous operation should be avoided. If the air is operated intermittently, or the positive and negative pressure of the pipeline needs to be continuously switched, the air valve switching method should be used.

If the vortex ZRV Blower is installed outdoors, please put a canopy above it to avoid rain. The cooling air vents should prevent foreign matter from being sucked into the blocking channel.

Please install the vacuum pump in a vibration-free location. If it must be installed in a place with vibration, it is necessary to install anti-vibration measures, pay attention to the use of hoses and rubber flanges and other connecting pipes to avoid damage to the ZRV Blower due to external vibration.

Please regularly clean the inside and outside of the air ring vacuum pump (especially the air passage of the cooling fan) to remove the dust on its surface. If a large amount of dust accumulates, the heat dissipation effect will become worse, and then the temperature will increase, the air volume will decrease, and the vibration will increase and cause malfunctions.

Bearings, oil seals, silencers, etc. are consumables, so they have a certain life span and need to be replaced regularly. At the same time, the impeller, casing, metal mesh, etc. also need to be replaced regularly according to the use environment.

If the operation is not smooth or abnormal noise occurs during operation, please turn off the power for inspection. If you need to disassemble the machine for maintenance during the warranty period, please notify our service personnel.

Note: In order to avoid the weight of the piping and other external loads, all concentrate the piping
Please add pipe brackets at appropriate places

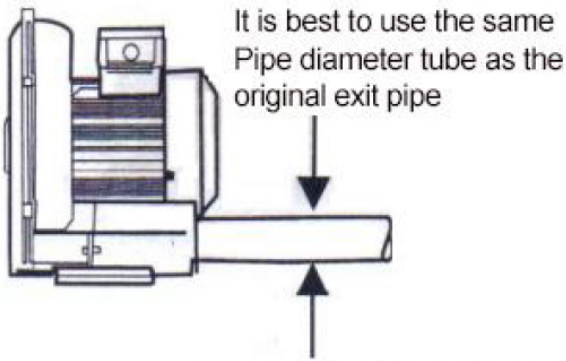

If the pipeline is too long or more, it needs to be configured to configure a coarse pipeline.

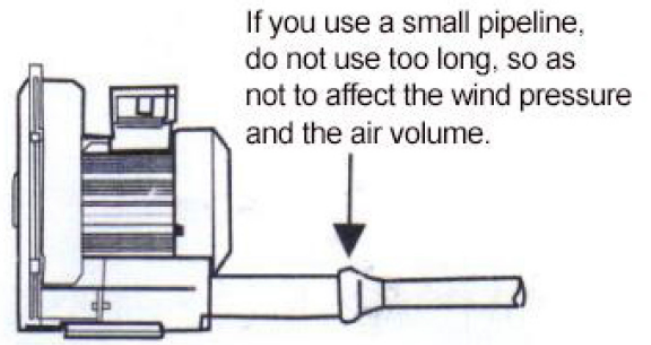

NOTES WHEN CONNECTING PIPE

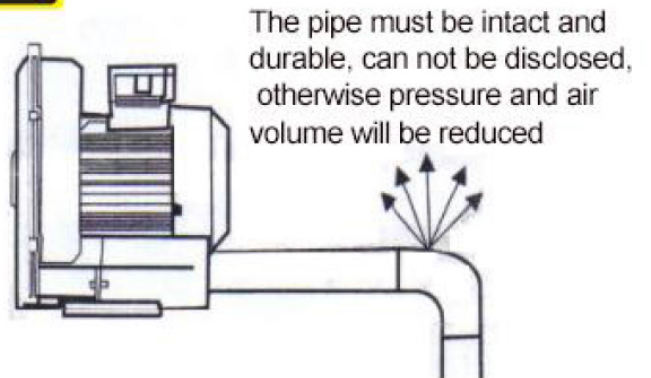
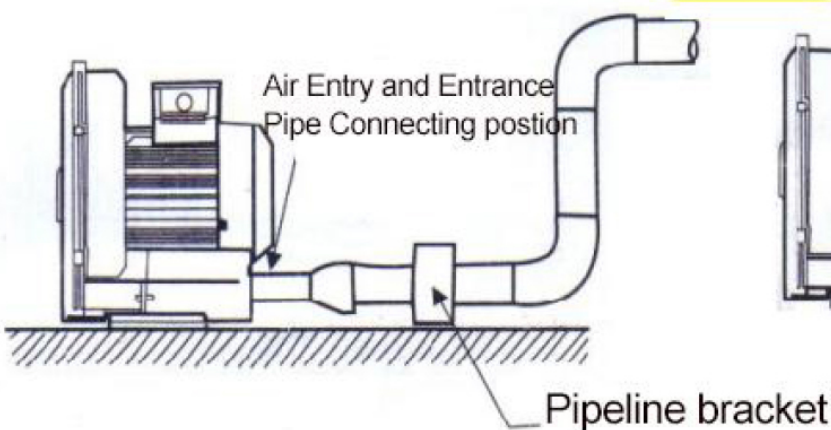

MAINTENANCE

WARNING



Machines contaminated with hazardous material.
Risk of poisoning!
Risk of infection!

If the machine is contaminated with hazardous material: Wear appropriate personal protective equipment.

CAUTION



Hot surface Risk of burns!

Prior to any action requiring touching the machine, let the machine cool down first.

Shut down the machine and lock against inadvertent start up.

Vent the connected lines to atmospheric pressure.

If necessary:

Disconnect all connections.

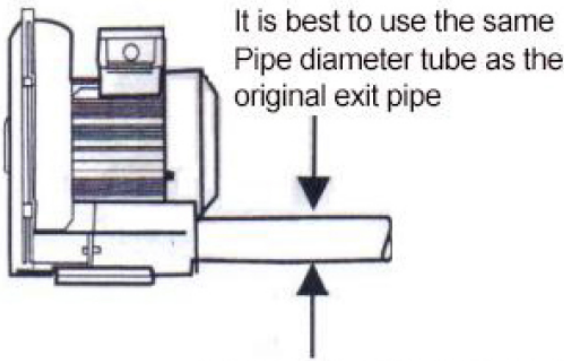

If the pipeline is too long or more, it needs to be configured to configure a coarse pipeline.

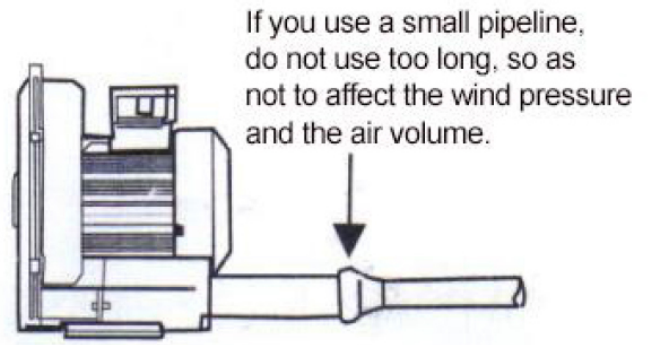

NOTES WHEN CONNECTING PIPE

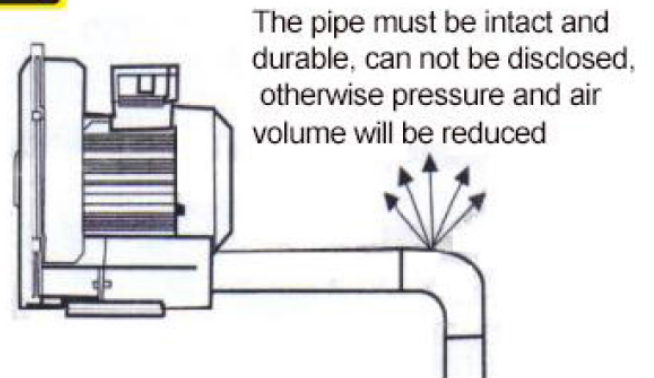
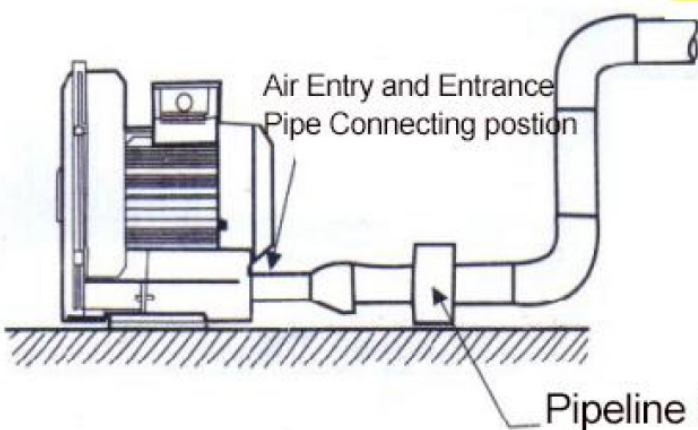

MAINTENANCE

WARNING



Machines contaminated with hazardous material.
Risk of poisoning!
Risk of infection!

If the machine is contaminated with hazardous material: Wear appropriate personal protective equipment.

CAUTION



Hot surface Risk of burns!

Prior to any action requiring touching the machine, let the machine cool down first.

Shut down the machine and lock against inadvertent start up.

Vent the connected lines to atmospheric pressure.

If necessary:

Disconnect all connections.

SPARE PARTS - NOTES



The use of non-genuine spare parts will lead to the risk of irreparable products.

Risk of premature failure! Loss of efficiency!

The exclusive use of genuine spare parts and consumables is recommended for the proper function of the machine and for granting of warranty.

Commercially available standard parts may be purchased from open market.

If other parts are required:

Contact your sales representative for the detailed spare parts and accessory list.

TROUBLESHOOTING



DANGER

Live wires. Risk of electrical shock!

Electrical installation work must only be executed by qualified personnel.



Hot surface. Risk of burns!

Prior to any action requiring touching the machine, let the machine cool down first

PROBLEM CHART		
PROBLEM	PROBABLE CAUSE	REMEDY
The machine does not start.	At least two power supply leads are interrupted The motor is not supplied with the correct voltage. The motor is defective.	Check the fuses, terminals and power supply cables. Check the power supply. Repair the machine (contact us).
The machine does not start; humming noise.	One power supply lead is interrupted Impeller defective Impeller is jammed Bearing on motor side machine side is defective	Check the fuses, terminals and power supply cables. Replace impeller. Open the cover, remove foreign body and clean. Check the impeller gap. Replace defective bearing.
Motor protective switch trips when starting the machine. Power consumption is too high.	Winding short-circuit Motor overloaded. Throttling does not match specification on rating plate Compressor is jammed	Check the winding. Reduce throttling. Clean Filters, mufflers and connecting pipes. See the machine does not start; humming noises.
The machine runs very noisily.	The machine runs in the wrong direction Bearing lacking grease Defective bearings	Check the direction of rotation. Relubricate or replace if necessary. Repair the machine (contact us).

TROUBLESHOOTING

PROBLEM CHART		
PROBLEM	PROBABLE CAUSE	REMEDY
The machine runs with abnormal flow noises.	The flow speed is too high. The silencers are soiled.	Use larger size pipes. Check silencer inserts, clean or replace if necessary.
The machine does not reach the usual pressure on the suction connection.	Suction or discharge lines too long or section diameter too small. The machine runs in the wrong direction. Different density of conveyed medium Change in blade profile due to soiling In case an inlet screen is installed: The inlet screen is partially clogged. In case a vacuum relief valve is installed: The vacuum relief valve is misadjusted or defective. In case an inlet filter is installed: The inlet filter cartridge is partially clogged. Leak in the system. Internal parts are worn or damaged.	Use larger diameter or shorter lines. Seek advice from your local sales representative. Check the direction of rotation, see wiring diagram Three-Phase Motor. Take conversion of pressure value into account. Contact us if necessary. Check the impeller, clean or replace if necessary. Clean the inlet screen. Replace the vacuum relief valve. Replace the inlet filter cartridge. Repair leak. Repair the machine (contact us).
The machine runs too hot	Insufficient cooling. Ambient temperature too high.	Remove dust and dirt from the machine. Observe the permitted ambient temperature.
Compressor leaky.	Seals on silencer defective Seals in motor area defective	Check silencer seals and replace if necessary. Check motor seals and replace if necessary.

For the solution of problems not mentioned in the troubleshooting chart contact your sales representative.

APPLICATION EXAMPLE USE FOR INDRAFT

• Blow Hoover exhaust cool transport air cushion

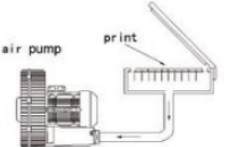
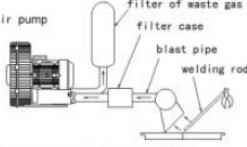
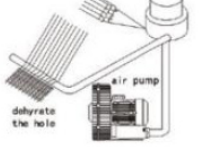
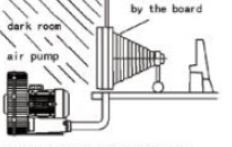
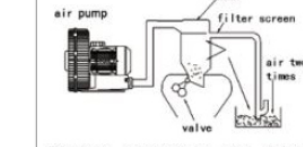
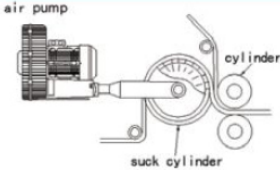
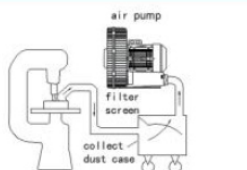
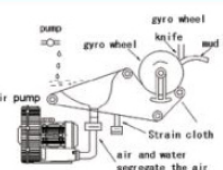
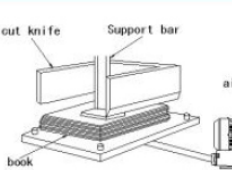
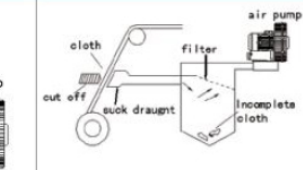
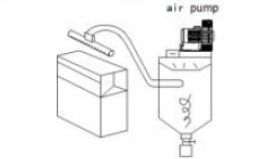
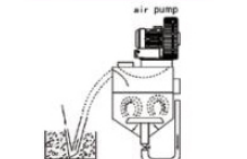
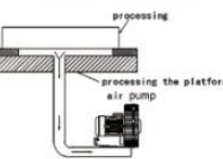
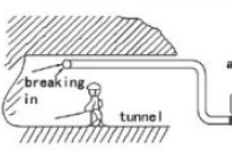
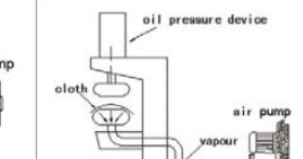
<p>The sucking of the printing machine of entwork edition</p>  <p>The sorption pressure fixed, in order to facilitate the printing operation</p>	<p>Eject the exhaust gas and dust produced while weldingdrawing</p>  <p>Smoke and dust whenwelding vacuum mode rowto the operator, ensure health</p>	<p>The wesve cottom machine suck silk</p>  <p>Absorbing moisture and fixed line, improve the quality of efficiency</p>	<p>Photo – engraving</p>  <p>Using vacuum suction force protection film, make flat, suitable for gravure industry</p>	<p>The powder body transports</p>  <p>Plastic materials and other granular objects, by blowing or sucking to transport</p>
<p>Print suck</p>  <p>Vacuum sorption printing or tissue formation to</p>	<p>Industry hoover</p>  <p>Factory always scrap residue on the machine, can smoke collection</p>	<p>Vacuum dehydrate</p>  <p>The pulp dehydration dehydration, pollution, cloth</p>	<p>Make books machine</p>  <p>When cutting the book sorption kept</p>	<p>Incomplete cloth deal with</p>  <p>Cloth cutting processing cutting cloth</p>
<p>Ox milk paper carton filling machine</p>  <p>Vacuum milk box filled with the attraction</p>	<p>Bean curd machinery</p>  <p>Draw soybean delivery, to the cleaning tank cleaning</p>	<p>Keeping processing</p>  <p>Wood, plastic and other non – magnetic objects fixed with</p>	<p>Defence works scenne</p>  <p>Tunnel with small work site, dust, poisonous gas, partial removall</p>	<p>Iron cloth machine</p>  <p>Press cloth will emit vapor</p>

APPLICATION EXAMPLE USE FOR BLOWING

• Blow Hoover exhaust cool transport air cushion

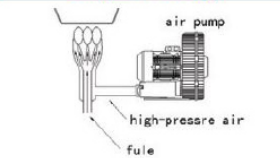
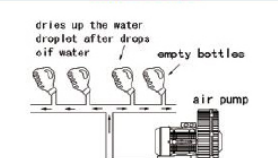
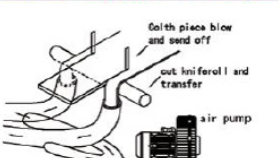
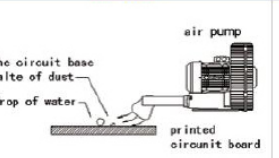
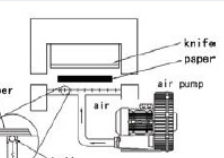
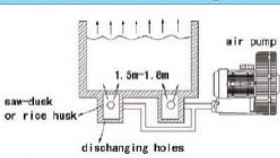
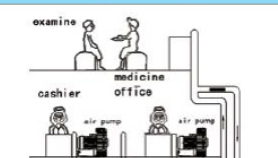
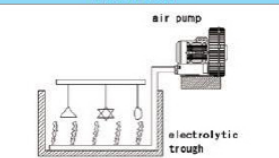
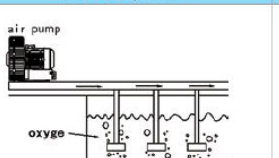
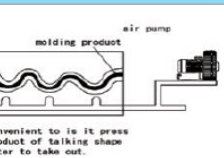
<p>The gas and heavy oil gush out firing</p>  <p>High pressure air (2.000mmaq) adequate ventilation, Will reduce your dependence on compressor</p>	<p>Wash the battle machine and dries up</p>  <p>Beverage bottle washing will drip dry, Applicable to the food industry</p>	<p>Can collect all the bits automatically after cut the Paper</p>  <p>Automatic collection of plastic, cloth, paper cutting edge</p>	<p>It is dry to use the air knife</p>  <p>The circuit board can be used to blow a small blower Dust and debris</p>	<p>Air cushion</p>  <p>increasing the buoyancy easy to move</p>
<p>The domestic animal excrement ferments' fiecness gas</p>  <p>High pressure air is blown intothe Storage fecal groove, increase the contact area,and also suitable for polluted wastewater treatment</p>	<p>Subpoena transport</p>  <p>t regards air as motive force to be fast also really to transport</p>	<p>The electrolytic liquid mix round</p>  <p>trough,make the electrolyte circulate, and repel adhering to the bubble and make electroplate rapady,the results is even.</p>	<p>The oxygen supply in breed aquatics</p>  <p>The exhaust gas blowsmoking</p>	<p>Puncher machine</p>  <p>convenient to is it press product of talking shape after to take out.</p>

Thank you again for choosing our ZRV Blower !

ZRV Blower



Single stage version



Two stage, For tougher requirements



Single stage For high pressure version



Multi-stage reliability for high differential pressure



CE RoHS

TEL: +90 212 656 29 08

MOBİL: +90 552 556 97 24

E-POSTA: info@zerovakum.com.tr

WEB SİTE: www.zerovakum.com.tr